

S3L2-Z564SP

18.4 kWm @ 2400 rpm | VARIABLE SPEED

MITSUBISHI DIESEL ENGINE

COMPACT AND RELIABLE

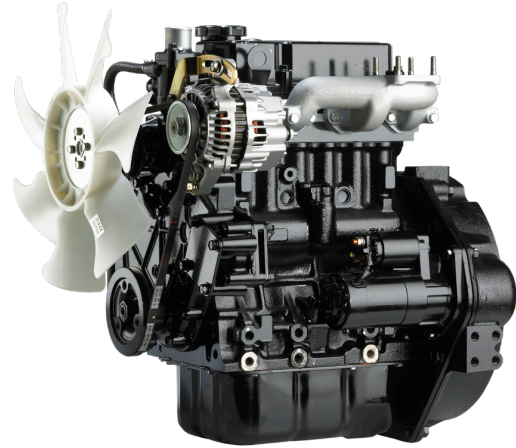

ENGINE DATA

Engine model	S3L2-Z564SP
Engine type	4-stroke, diesel
Cylinder configuration	3 in-line
Bore x stroke (mm)	78 x 92
Total displacement (l)	1.318
Aspiration	natural
Dry weight (kg)	135
Emission	EU Stage V

Cooling system	water-cooled, forced circulation by centrifugal pump with thermostat
Combustion system	indirect injection, swirl chamber type
Fuel injection system	pump-line-nozzle (in-line pump)
Electrical system (V / A)	12 / 65
Starting system (V / kW)	12 / 1.7
Rotation (ISO 1204)	counterclockwise
Flywheel and housing	semi: SAE 7.5" / SAE #5

RATING¹

	Gross	Net
	w/o fan	with fan
Output (kWm)	18.4	17.7
Output (bhp)	24.7	23.7
Engine speed (rpm)	2400	

Gross

Fuel consumption 100% load (g/kWh) ²	270
Max. torque (Nm)	76.3
Side gear PTO (Nm)	39.2

¹ Rating definition according ISO3046, rating tolerance ±5% of nominal. ² Fuel consumption is based on ISO3046/1 with ±8% tolerance at 100% rated power.

PERFORMANCE CURVE

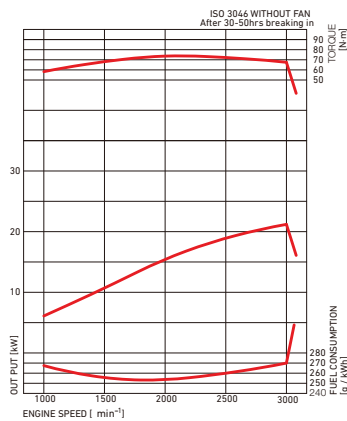

DIMENSIONS

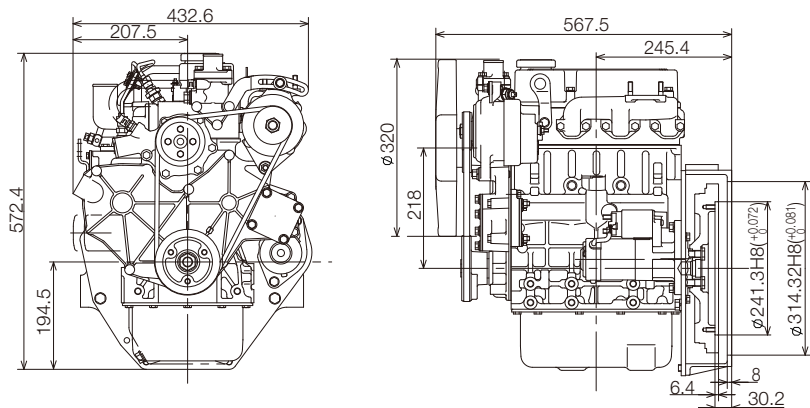

More information

Contact your local dealer for more information regarding Mitsubishi Diesel Engines and optional equipment or, visit www.mtee.eu/engines

MOVE THE WORLD FORWARD **MITSUBISHI
HEAVY
INDUSTRIES
GROUP**

© Mitsubishi Turbocharger and Engine Europe B.V. | This specification may be revised without prior notice. All pictures shown are for illustration purpose only.